

Physics 101

Lab 10: Equilibrium

Myat Thit Ko Ko

Date: 04/23/2026

Contents

	Pages
Purpose	3
Members	3
Procedure	3
Data & Analysis	4
Conclusion	10
Summary	10

Purpose

The purpose of this eighth lab is to obtain practical skills in performing an experiment to achieve an equilibrium of tension and gravity where net torque is zero. The goal is to figure out the exact angles of torque that allow tension to be at expected value.

Members

This lab group consisted of four members who worked together as a team to make the procedure accurate and fair for everyone.

1. Myat Thit Ko Ko (author)
2. Sarah Ruelas
3. Inigo Mikael Dela Vega
4. Hector Torres

Procedure

The lab consisted of the following steps and procedures.

- Measuring mass of the meter long ruler

Case I

- Adding weight to the hanging object to achieve equilibrium
- Measuring mass of the hanging object.

Case II

- Adding weight to the hanging object to achieve equilibrium.
- Measuring mass of the hanging object.

Case III

- Measuring mass of the rectangular block.
- Adding weight to the hanging object to achieve equilibrium.
- Measuring mass of the hanging object.

Data & Analysis

Case I

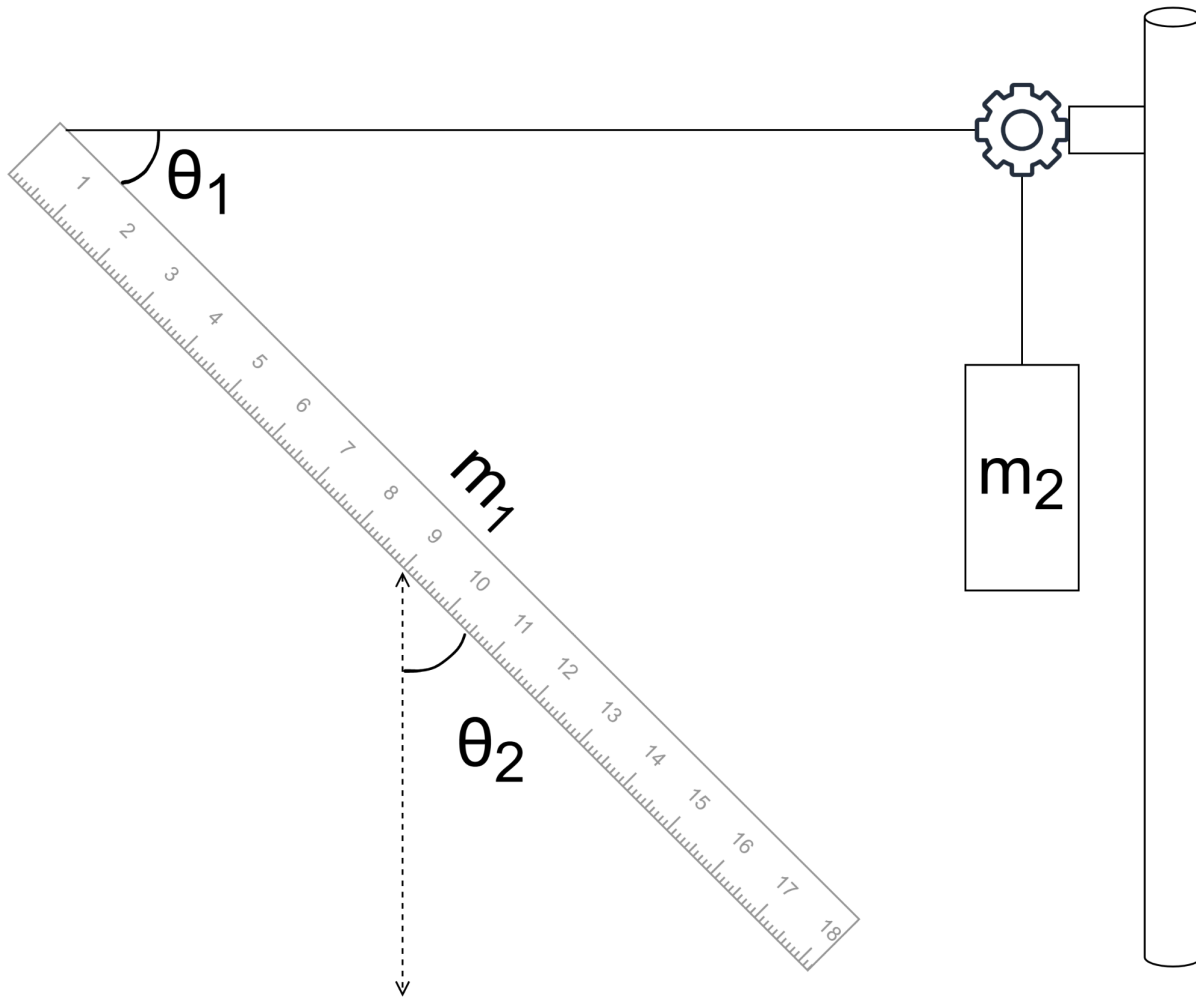

Illustration of case 1 set up



Mass 1 & Mass 2

Theta 1 = 38 degrees

Theta 2 = 52 degrees

$m_1 = 0.15535 \text{ kg}$

$m_2 = 0.1005 \text{ kg}$

$$\text{Tension}_{\text{exp}} = m_2 g = 0.1005 \text{ kg} \times 9.8 \text{ m/s}^2 = 0.985 \text{ N}$$

$$\text{Torque} = m_1 g \sin \theta_2 (\text{length}/2) - \sin \theta_1 (\text{length}) (\text{Tension})_{\text{theo}} = 0$$

$$\text{Tension}_{\text{theo}} = \frac{m_1 g \sin \theta_2}{2 \sin \theta_1} = \frac{(0.15535 \text{ kg})(9.8 \text{ m/s}^2)(\sin 52^\circ)}{2 \sin (38^\circ)} = 0.974 \text{ N}$$

$$\% \text{ error} = \frac{|0.985 - 0.974|}{\frac{0.985 + 0.974}{2}} = 1.12 \%$$

Case II

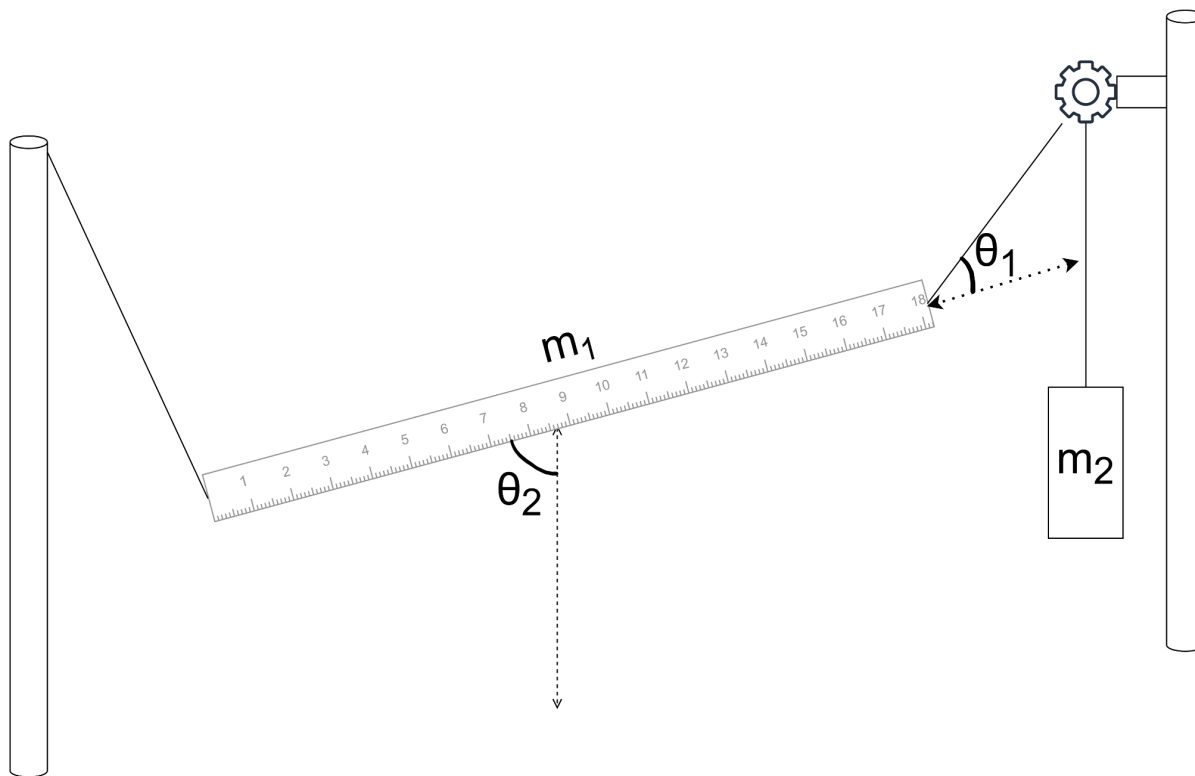
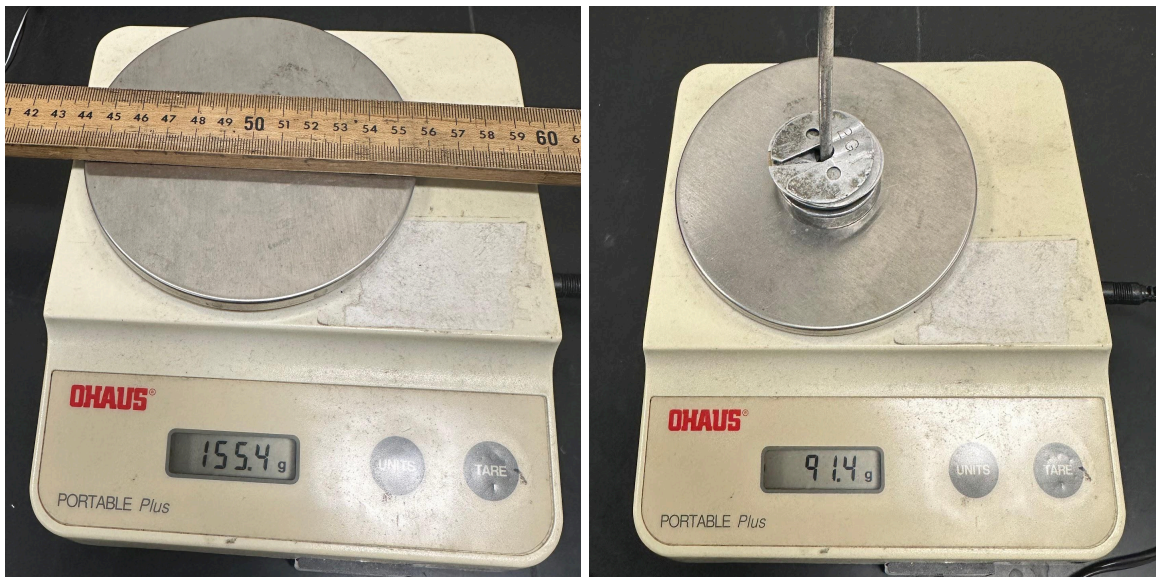

Illustration of case 2 set up



Mass 1 & Mass 2

Theta 1 = 57 degrees

Theta 2 = 72 degrees

$m_1 = 0.15535 \text{ kg}$

$m_2 = 0.0914 \text{ kg}$

$$\text{Tension}_{\text{exp}} = m_2 g = (0.0914 \text{ kg})(9.8 \text{ m/s}^2) = 0.8957 \text{ N}$$

$$\text{Tension}_{\text{theo}} = \frac{m_1 g \sin \theta_2}{2 \sin \theta_1} = \frac{(0.15535 \text{ kg})(9.8 \text{ m/s}^2)(\sin 72^\circ)}{2 \sin(57^\circ)} = 0.8632 \text{ N}$$

$$\% \text{ error} = \frac{|0.8632 - 0.8957|}{\frac{0.8632 + 0.8957}{2}} = 3.70 \%$$

Case III

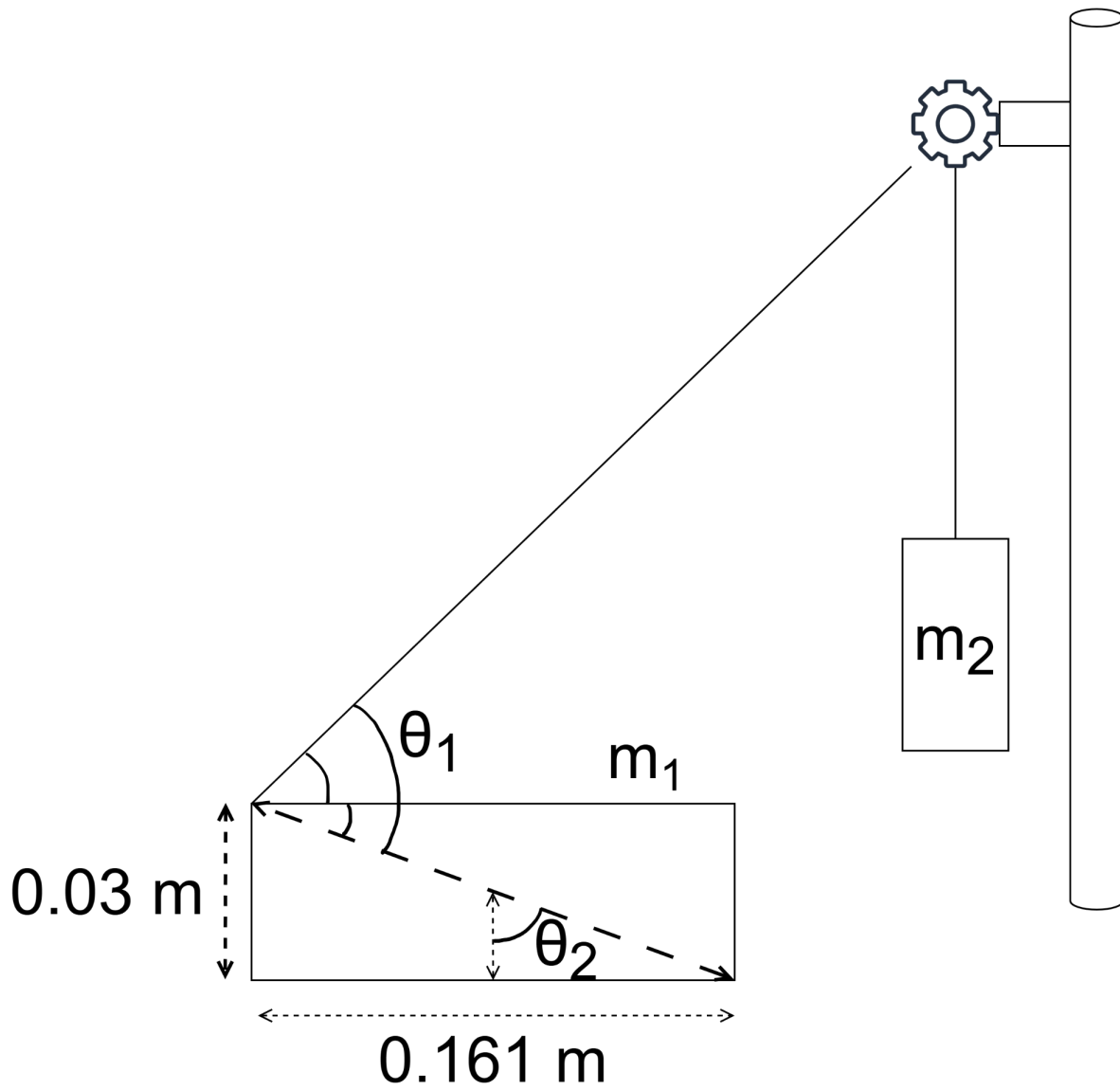

Illustration of case 3 set up



Mass 1 & Mass 2

Theta 1 = 64 degrees

Theta 2 = 81 degrees

$m_1 = 0.2530 \text{ kg}$

$m_2 = 0.1405 \text{ kg}$

$$\text{Tension}_{\text{exp}} = m_2 g = (0.14055 \text{ kg}) (9.8 \text{ m/s}^2) = 1.377 \text{ N}$$

$$\text{Tension}_{\text{theo}} = \frac{m_1 g \sin \theta_2}{2 \sin \theta_1} = \frac{(0.2530 \text{ kg}) (9.8 \text{ m/s}^2) (\sin 81^\circ)}{2 \sin(64^\circ)} = 1.362 \text{ N}$$

$$\% \text{ error} = \frac{|1.362 - 1.377|}{\frac{1.362 + 1.377}{2}} = 1.10\%$$

Analysis

All error percentages were below 5%. Low error percentage is likely due to accurate measurement of angles and almost frictionless nature of the pulleys.

Conclusion

Since error percentages were found to be less than 10%, this lab is deemed satisfactory. This lab was rather fun because of the teamwork during the process of achieving equilibrium by stacking weights.

Summary

Experiment Title: Equilibrium

Student's name: Myat Thit Ko Ko

Date: 04/23/2026

Purpose: To compare the values of tension on string derived by hanging mass and by net torque.

Procedure: Measuring data, stacking weights, calculating values.

Data: $1 \times 3 = 3$ points total

Analysis: Error percentages were 1.12%, 3.70%, and 1.10% respectively.

Conclusion: Satisfactory